

# SERVICE DATA:MEF15/20C

## Dimensions

H:Tiller Handle Model

RC:Remote Control Model

PT:PT Model

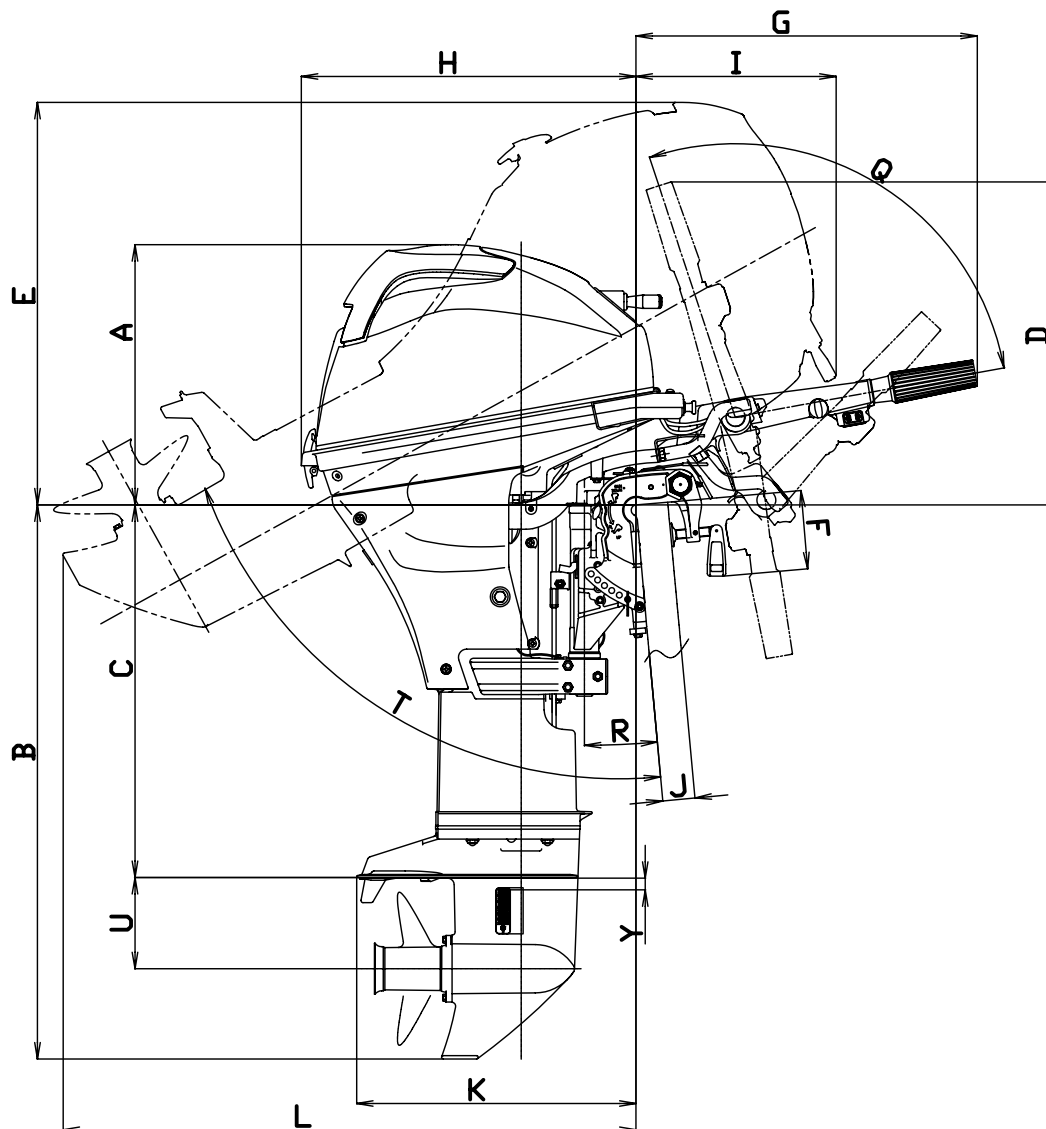
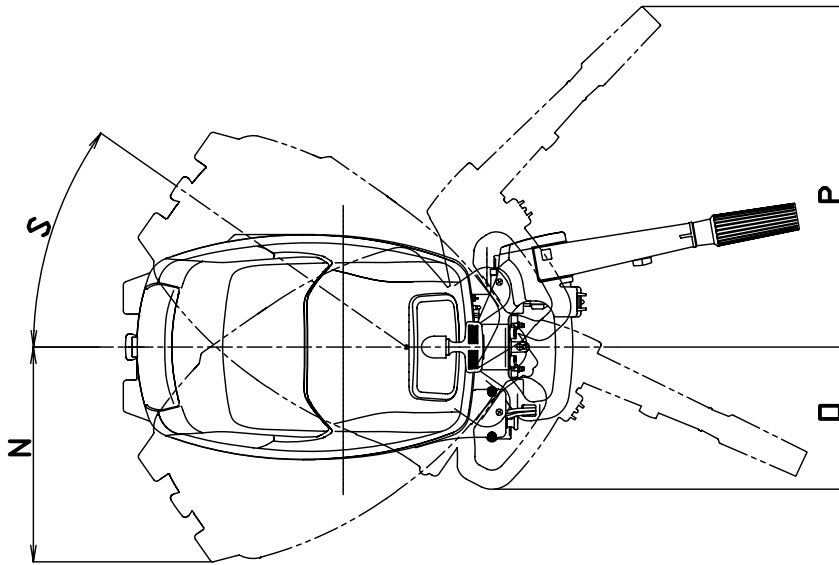

| ITEM                       | Transom  | UNITS | Approx.       |
|----------------------------|----------|-------|---------------|
| A                          |          | mm    | 398           |
| B                          | S        | mm    | 690           |
|                            | L        | mm    | 840           |
|                            | UL       | mm    | 967           |
| C                          | S        | mm    | 413           |
|                            | LL       | mm    | 562           |
|                            | UL       | mm    | 689           |
| D                          |          | mm    | 490           |
| E                          |          | mm    | 610           |
| F                          |          | mm    | 120           |
| G                          | H        | mm    | 520           |
|                            | H (Tilt) | mm    | 495           |
| H                          |          | mm    | 510           |
| I                          |          | mm    | 305           |
| J                          |          | mm    | 40-60         |
|                            | PT       | mm    | 30-63         |
| K                          |          | mm    | 425           |
| L                          | S        | mm    | 740           |
|                            | L        | mm    | 880           |
|                            | UL       | mm    | 915           |
| M                          | H        | mm    | 390           |
|                            | RC       | mm    | 345           |
| N                          |          | mm    | 325           |
| O                          | H        | mm    | 215           |
| P                          | H        | mm    | 520           |
| Q                          | H        | deg.  | 98            |
| R                          |          | deg.  | 9             |
| S                          |          | deg.  | 35            |
| T                          |          | deg.  | 70            |
|                            | PT       | deg.  | 71            |
| U                          |          | mm    | 140           |
| V                          |          | mm    | 215           |
| W                          |          | mm    | 194           |
| X                          |          | mm    | 78            |
|                            | PT       | mm    | 111           |
| Y                          |          | mm    | 15            |
| Trim angle (Position)      |          | deg.  | 5°-25°<br>(6) |
| Trim angle : PT (Position) |          | deg.  | 4°-16°<br>(5) |

